

# ***Exploring Tactile Resonance Sensors: The Revolutionary Force and Challenges in the Medical Field***

**Tianze Yu**

*Nanjing Agricultural University, Nanjing, China*  
*3441634743@qq.com*

**Abstract:** In the past few decades, with the gradual maturation of robotics, especially in medical applications, tactile sensors based on various sensing principles have been developed. A multitude of technical solutions have been employed to design tactile sensors. Notably, microfabrication-based approaches possess several appealing features. Microfabrication technology enables the development of miniature sensors with excellent performance, which exhibit outstanding metrological characteristics, such as high precision, sensitivity, low power consumption, and favorable frequency response. The compact size and superior metrological properties enhance the potential role of tactile sensors in the medical field, particularly resonance sensors (TRS). Its principle involves measuring the frequency shift  $\Delta f$ , defined as the difference between the resonance frequency of the freely vibrating sensor and the resonance frequency measured when the sensor encounters an object. Therefore,  $\Delta f$  is related to the acoustic impedance of the object and can be utilized to characterize its material properties. In the medical domain, tactile resonance sensor systems have been developed for various applications, including cancer detection, assessment of human egg fertility, measurement of intraocular pressure, and diagnosis of edema. In this review, we mainly explore the basic principles, major medical applications, technological advancements, and challenges of TRS. TRS shows remarkable potential in medical application. Although innovations in sensor design and materials have expanded its functions, issues such as signal interference, lack of standardization, and insufficient clinical verification still need to be addressed. Overcoming these challenges is essential for realizing the full potential of TRS in improving medical diagnosis and patient care.

**Keywords:** Tactile sensors, minimally invasive surgery, medicine, prosthetics

## **1. Introduction**

In the field of biomedical engineering, non-invasive and real-time assessment of tissue mechanical properties has long been an important yet highly challenging research area. Traditional assessment methods, such as invasive biopsies and imaging techniques, although valuable, have significant limitations. Biopsy, regarded as the gold standard in many cases, is an invasive procedure, entailing risks of infection, bleeding, and other complications. Imaging techniques, while non-invasive, struggle to obtain tissue stiffness information in real-time with high fidelity. Tissue stiffness, as a crucial biomarker, plays a vital role in disease diagnosis and progression monitoring. The lack of accurate assessment of tissue stiffness restricts the accuracy and timeliness of clinical diagnosis.

Tactile resonance sensors (TRSs), as a new type of transducer, offer novel solutions for the assessment of tissue mechanical properties. TRSs operate based on the piezoelectric effect, where certain materials generate electrical signals when subjected to mechanical forces [1]. By detecting minute changes in resonance frequencies, TRSs are capable of quantitatively analyzing the viscoelastic properties of tissues, providing an innovative and effective approach for tissue characterization.

In recent years, with the rapid advancements in piezoelectric material science, micro-nano fabrication technology, and computational signal processing techniques, remarkable progress has been made in the research of TRSs. Researchers have developed various high-performance sensors by optimizing material properties and manufacturing processes. For instance, the development of flexible lead zirconate titanate (PZT) thin films enables better adaptation to complex anatomical structures, thereby enhancing the accuracy of *in vivo* measurements [2]. Sensors based on zinc oxide (ZnO) nanorods have significantly improved detection sensitivity [3]. Additionally, the integration of machine learning algorithms has further enhanced the data analysis capabilities of TRSs, substantially boosting their diagnostic efficacy [4].

Despite the numerous achievements in TRS research, several challenges remain in the process of practical application and promotion. Environmental factors can significantly affect sensor performance, leading to unstable and unreliable measurement results. The absence of unified calibration standards in the industry makes it difficult to effectively compare the performance of different TRS systems. More critically, there is a lack of sufficient clinical evidence. Without adequate validation of effectiveness, it is challenging for medical practitioners to incorporate TRSs into routine clinical practice. This paper aims to provide a comprehensive review of the current research status of TRS technology, conduct an in-depth analysis of its advantages, limitations, opportunities, and challenges, and propose directions for future research and development, thereby promoting the further improvement and widespread application of TRS technology.

## 2. Basic principles and technical foundations

### 2.1. Mechanism of tactile resonance sensors

TRS operates based on the principle of piezoelectric resonance. Piezoelectric materials, such as lead zirconate titanate (PZT) and zinc oxide (ZnO), generate electrical signals under mechanical stress. When TRS encounters a material, due to the different contact impedance ( $Z_x$ ) between the hemispherical sensor head and the object, the resonance characteristics of PZT change. The shift ( $\Delta f$ ) between the free-state resonance frequency and the frequency when in contact with the tissue is a key parameter for characterizing the mechanical properties of the tissue [2].

The piezoelectric sensing principle leads to the sandwich structure being the common sensing structure of piezoelectric tactile sensors. The piezoelectric layer is deposited between two electrode layers. Similar to capacitive tactile sensors (as shown in figure 1), raised structures like mesas and spheres have been integrated as contact facilitators. For piezoelectric tactile sensors, the electrical readout circuit shows changes in voltage or current according to the variation of external stress or frequency shift.

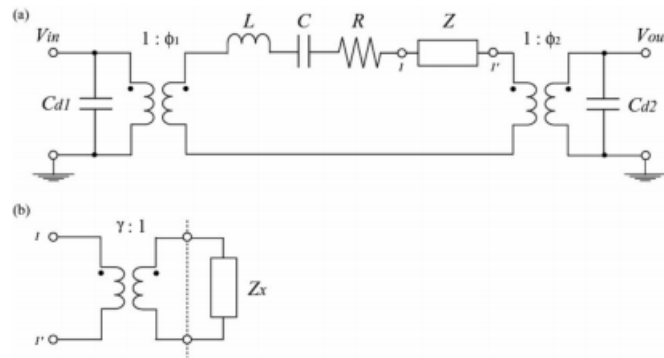

Figure 1: Equivalent circuit of the tactile resonance sensor [2]

Recent research efforts have been dedicated to developing new piezoelectric materials and sensor designs to enhance sensitivity and biocompatibility. Flexible PZT thin films and ZnO nanowires have been used to conform to irregular tissue surfaces, such as for real-time monitoring of arterial pulsation and intraocular pressure. Additionally, advanced signal processing techniques, such as phase-locked loops and machine learning, are used to accurately measure  $\Delta f$ . Machine learning models, such as artificial neural networks, have demonstrated high accuracy in tactile position recognition, improving the overall performance of TRS.

## 2.2. Comparison with traditional pressure sensors

When measuring stiffness using the traditional stress-strain method, on one hand, a force is applied to the object, and the relative displacement between the force sensor and the object is measured, which means the object needs to maintain mechanical stability. On the other hand, tactile resonance sensors measure the force and the contact area between the hemispherical sensor tip and the object by detecting the change in the sensor's (as shown in Figure 2) resonance frequency. These two parameters can be measured without the requirement of the object's mechanical stability. In other words, tactile resonance sensors (TRS) can measure stiffness through a "brief contact" with the object.

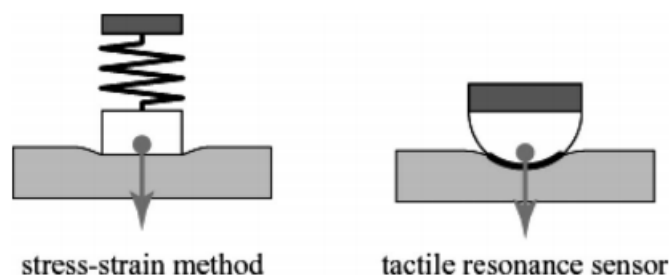

Figure 2: Comparison of the stiffness measurement methods

This enables TRS to respond with varying sensitivities when measuring different areas, achieving a broader dynamic response range. [1] With the stress-strain method, the object must be mechanically stable during measurement, whereas with the tactile resonance method, the object does not need to be stable [2].

### 3. Medical applications of TRS

#### 3.1. Cancer detection

TRS shows significant potential in cancer detection, especially in the diagnosis of prostate cancer. Traditional prostate cancer detection relies on the PSA test and digital rectal examination (DRE). However, invasive biopsies still miss 10–30% of prostate cancer (PCa) cases. Since DRE results are subjective and depend on the experience of physicians, an objective method with quantitative parameters for prostate tissue stiffness is urgently required.

Resonance sensor systems with hemispherical contact tips have the potential to detect changes in the hardness of prostate tissue around the sensor tip. These changes in measured hardness are due to the spatial variations in the histology of the prostate tissue beneath and beside the tip [5]. Tactile resonance sensors can measure the stiffness on or near the surface of surgically excised human prostate tissue. Studies have evaluated the measurement considerations for prostate tissue applications, including comparisons with tissue phantoms and gold-standard histopathology, aiming to improve diagnostic accuracy.

Research indicates that TRS can accurately distinguish cancerous from normal prostate tissue by measuring tissue stiffness. In vitro experiments have successfully identified silicone hard lumps simulating tumors (up to 4 mm below the tissue surface). Clinical trials have also shown a high sensitivity in distinguishing cancerous areas ( $p < 0.05$ ), suggesting that TRS may replace invasive biopsies. In addition, TRS has been used for the detection of liver fibrosis and lymph node metastasis [4].

#### 3.2. Minimally invasive surgery and prosthetics

Since the 1990s, extensive research efforts have been invested in the development of minimally invasive surgical tools, including minimally invasive surgery (MIS), endoscopic and laparoscopic surgery, and robot-assisted minimally invasive surgery. These surgical methods have advantages over traditional surgery in reducing intraoperative bleeding, tissue damage, the risk of postoperative infection, patient pain, and postoperative recovery time. However, minimally invasive surgery places more operational difficulties and pressure on surgeons, such as limited space due to small incisions, reduced degrees of freedom during operation, and the lack of tactile feedback when tools encounter tissues. To provide information about the different properties of tissues undergoing minimally invasive surgery, TRS integrated into robotic surgical tools can provide real-time feedback on tissue stiffness [6], improving resection accuracy. A piezoelectric tactile sensor that can adapt to any contact angle achieved an accuracy of 92% in distinguishing hard lumps from normal tissues in simulated surgeries, overcoming the limitations of traditional force sensors [7].

In the field of prosthetics, TRS can help users estimate the magnitude and direction of the applied force, distinguish the specific position where the force acts on the contact surface, and evaluate the compliance and texture properties of the manipulated object [7]. Moreover, its dynamic behavior should be comparable to the response of human mechanoreceptors to time-varying tactile stimuli. Especially during grasping and manipulation, detecting slippage is a fundamental requirement to enhance grip stability and hand dexterity. Flexible TRS based on ZnO nanowires can mimic the sensitivity of human skin, enabling prosthetic users to perceive pressure and texture. Such sensors can also be used to monitor muscle activity and joint movement during rehabilitation.

It is worth noting that tactile sensors are designed to acquire information through physical contact. Therefore, other physical quantities and properties, such as temperature, slip, vibration, shape, and texture, can also be measured by tactile sensors.

### 3.3. Oocyte recognition

Since TRS works based on the relative displacement method, it can achieve highly sensitive tactile perception, enabling it to measure the elasticity of extremely small samples. Changes in egg stiffness may play an important role in identifying different fertilization stages. As single cells, eggs present unique challenges in determining their fertilization status due to stiffness variations. [8] Structurally, eggs are surrounded by a zona pellucida (ZP), a glycoprotein cell outer layer about 15 micrometers thick, and the elasticity of the ZP is believed to change during fertilization (zona pellucida hardening), a process known as the zona pellucida reaction. A micro-tactile sensor (MTS) was developed and optimized to measure elasticity at the microscale [9]. Using this novel MTS, the elasticity of the ZP was evaluated for the first time, and the zona pellucida hardening was demonstrated for the first time [2].

In subsequent research, the authors improved their tactile resonance sensor to measure another variable: "contact time." The unique method developed by these authors first conducted a finite modal analysis of the MTS to determine the frequencies at which both longitudinal and rotational vibration modes exist simultaneously. Then, the MTS was made to oscillate in these two vibration modes. The resonance mode of the main longitudinal vibration changes with indentation and elasticity, while the rotational mode suddenly disappears upon contact, thus changing the resonance frequency, indicating the duration of "touch" [10,11].

## 4. Industrial applications

Unlike traditional industrial robots, such as robotic arms, which follow predefined and simple programs, intelligent robots are designed to work autonomously and interact with the surrounding environment. This requires intelligent robots to be able to perceive and interpret the environment with the aid of various sensors. Tactile perception is crucial for the safe interaction between robots and the surrounding environment, as it provides the most direct tactile feedback to control the force during the interaction process. Research shows that in unstructured environments where many other sensing methods, such as vision or hearing, are limited, remote tactile perception is more advantageous.

In recent years, remarkable progress has been made in TRS technology. Wireless TRS based on radio frequency (RF) resonators has been introduced, enhancing mobility and facilitating its integration into wearable devices and soft robots. A wireless flexible TRS array combined with machine learning perception achieved an accuracy of 98.5% in robot object recognition tasks [12].

Multimodal and multifunctional sensors, such as PZT sensors integrated with temperature-sensitive materials, can simultaneously measure tissue stiffness and thermal properties, improving diagnostic accuracy. Microfabrication techniques, such as photolithography and sol-gel deposition, have enabled the miniaturization of TRS. High-resolution TRS arrays have been integrated into endoscopic tools; for example, a 100- $\mu\text{m}$  resolution array is used for tissue stiffness mapping during prostatectomy.

## 5. Challenges and future prospects

### 5.1. Challenges

Despite its significant potential, TRS confronts a multitude of challenges in practical applications. Firstly, signal interference is a prominent issue. Signals and noise from environmental and electromagnetic sources can distort resonance frequency measurements. For instance, in complex medical environments, electromagnetic signals emitted by various electronic devices may interfere with the measurements of TRS, resulting in inaccurate data. To address this, the development of advanced filtering algorithms and the design of shielded sensors are required [13].

Secondly, in clinical applications such as cancer lesion resection, TRS has obvious drawbacks. It is extremely sensitive to load changes but less responsive to manual operations, and its spatial resolution is insufficient to precisely define resection boundaries. Take tumor resection surgery as an example; surgeons cannot accurately determine the resection range based on the information provided by TRS, affecting the surgical outcome [1].

Thirdly, biocompatibility and long-term stability are of vital importance for implantable TRS. Although materials like polydimethylsiloxane (PDMS) and degradable polymers show promise, further research is needed to ensure their long-term performance within the human body. Meanwhile, the lack of standardized calibration protocols complicates the comparison of different TRS, and there is an urgent need to establish universal calibration methods and reference materials.

Finally, most current TRS research is based on in vitro or animal models. However, large-scale clinical trials are essential to truly verify its effectiveness in humans.

## 5.2. Future directions

There are clear and highly promising directions for the future development of TRS. On the one hand, large-scale clinical research is crucial. By conducting large-scale clinical trials and collecting extensive human data, we can more accurately evaluate the effectiveness of TRS in actual medical scenarios, providing solid data support and scientific evidence for its clinical application and promoting the transition of TRS from laboratory research to clinical practice.

On the other hand, the integration with artificial intelligence and robotics will be an important trend. Combining TRS with artificial intelligence and robotics is expected to promote the development of autonomous surgical systems. Machine learning algorithms can analyze sensor data collected by TRS in real time and provide intelligent guidance for surgical decisions. For example, during complex surgeries, algorithms can quickly process a large amount of data, helping surgeons make more precise decisions, improving the safety and success rate of surgeries, and thus revolutionizing traditional surgical models.

## 6. Conclusion

Tactile resonance sensors stand at a crossroads in the history of biomedical engineering, on the verge of a new era that could redefine the way we approach disease diagnosis and treatment. Through this in-depth review of 13 key studies, we have peeled back the layers of TRS technology, exploring its fundamental principles, diverse medical applications, and the latest technological innovations. The potential of TRSs is undeniable—they can transform cancer detection from an invasive and often anxiety-inducing process into a non-invasive, more accessible screening method. In the operating room, they can enhance the precision of minimally invasive surgeries, making procedures safer and more effective. And for amputees, they offer the hope of regaining a sense of touch, bridging the gap between the body and the external world.

However, the path to realizing this potential is fraught with challenges. Technical hurdles such as signal interference, the need for biocompatible materials, and the establishment of standardized calibration protocols require concerted efforts from the research community. The lack of extensive clinical validation also means that TRSs are not yet ready for prime time in many healthcare settings. But these challenges should not be seen as insurmountable roadblocks; rather, they represent opportunities for innovation and growth.

As researchers continue to push the boundaries of materials science, sensor design, and signal processing, the future of TRSs is filled with promise. The convergence of TRSs with emerging technologies like AI and robotics holds the key to unlocking new possibilities. With continued collaboration between academia, industry, and clinical stakeholders, there is every reason to believe

that TRSs will not only overcome the current challenges but also become an indispensable part of routine medical practice. In the not-too-distant future, these sensors could be the silent heroes in healthcare, improving patient outcomes, reducing the burden of disease, and transforming the very fabric of modern medicine.

## References

- [1] T. Hemsel, R. Stroop, D. Oliva Uribe, and J. Wallaschek, "Resonant vibrating sensors for tactile tissue differentiation," *Journal of Sound and Vibration*, vol. 308, no. 3-5, pp. 441–446, 2007, doi: 10.1016/j.jsv.2007.03.063.
- [2] O. A. Lindahl, C. E. Constantinou, A. Eklund, Y. Murayama, P. Hallberg, and S. Omata, "Tactile resonance sensors in medicine," *J Med Eng Technol*, vol. 33, no. 4, pp. 263–73, 2009, doi: 10.1080/03091900802491188.
- [3] L. Zou, C. Ge, Z. J. Wang, E. Cretu, and X. Li, "Novel Tactile Sensor Technology and Smart Tactile Sensing Systems: A Review," *Sensors (Basel)*, vol. 17, no. 11, Nov 17 2017, doi: 10.3390/s17112653.
- [4] H. J. Tseng, W. C. Tian, and W. J. Wu, "Flexible PZT thin film tactile sensor for biomedical monitoring," *Sensors (Basel)*, vol. 13, no. 5, pp. 5478–92, Apr 25 2013, doi: 10.3390/s130505478.
- [5] V. Jalkanen, B. M. Andersson, A. Bergh, B. Ljungberg, and O. A. Lindahl, "Spatial variations in prostate tissue histology as measured by a tactile resonance sensor," *Physiol Meas*, vol. 28, no. 10, pp. 1267–81, Oct 2007, doi: 10.1088/0967-3334/28/10/011.
- [6] A. P. Astrand, B. M. Andersson, V. Jalkanen, B. Ljungberg, A. Bergh, and O. A. Lindahl, "Prostate Cancer Detection with a Tactile Resonance Sensor—Measurement Considerations and Clinical Setup," *Sensors (Basel)*, vol. 17, no. 11, Oct 26 2017, doi: 10.3390/s17112453.
- [7] Y. F. Liu, W. Wang, and X. F. Chen, "Progress and prospects in flexible tactile sensors," *Front Bioeng Biotechnol*, vol. 11, p. 1264563, 2023, doi: 10.3389/fbioe.2023.1264563.
- [8] Y. Zhang, F. Ju, X. Wei, D. Wang, and Y. Wang, "A Piezoelectric Tactile Sensor for Tissue Stiffness Detection with Arbitrary Contact Angle," *Sensors (Basel)*, vol. 20, no. 22, Nov 18 2020, doi: 10.3390/s20226607.
- [9] N. Bandari, J. Dargahi, and M. Packirisamy, "Tactile Sensors for Minimally Invasive Surgery: A Review of the State-of-the-Art, Applications, and Perspectives," *IEEE Access*, vol. 8, pp. 7682–7708, 2020, doi: 10.1109/access.2019.2962636.
- [10] P. Saccomandi, E. Schena, C. M. Oddo, L. Zollo, S. Silvestri, and E. Guglielmelli, "Microfabricated tactile sensors for biomedical applications: a review," *Biosensors (Basel)*, vol. 4, no. 4, pp. 422–48, Dec 2014, doi: 10.3390/bios4040422.
- [11] M. A. Yousuf and B. A. Asiyanbola, "A review of force and resonance sensors used in the clinical study of tissue properties," *Proc Inst Mech Eng H*, vol. 227, no. 12, pp. 1333–40, Dec 2013, doi: 10.1177/0954411913493722.
- [12] B. Xu et al., "Wireless and Flexible Tactile Sensing Array Based on an Adjustable Resonator with Machine-Learning Perception," *Advanced Electronic Materials*, vol. 9, no. 6, 2023, doi: 10.1002/aelm.202201334.
- [13] M. Maezawa, T. Imahashi, Y. Kuroda, H. Adachi, K. Yanagisawa, and IEEE, "Tactile sensor using piezoelectric resonator," in *1997 International Conference on Solid-State Sensors and Actuators, Chicago, IL, 1997, Jun 16–19 1997, 1997*, pp. 117–120. [Online]. Available: <Go to ISI>://WOS:A1997BJ35B00026. [Online]. Available: <Go to ISI>://WOS:A1997BJ35B00026