

Natural Language Processing and Deep Learning in Cross-Cultural Language Acquisition: From Machine Translation to Cultural Context Understanding

Yang Chao^{1,a,*}

¹*FAFU-Dal Joint College, Fujian Agriculture and Forestry University, Fujian, China*

a. yc1999@fafu.edu.cn

**corresponding author*

Abstract: Our research examines how Natural Language Processing and Deep Learning methods help learners better understand foreign languages and cultures. Our research showed that advanced language technology tools including machine translation speech recognition and sentiment analysis help students learn both language skills and cultural understanding better. Our research team tested 100 participants across English, Chinese, and Spanish with 50 participants in each group. The experimental group studied with NLP and DL platform-based language learning platforms but the control group used traditional education methods. Researchers tested cultural knowledge and language skills for 12 weeks by giving tests before and after the experiment. The experimental group made better progress in speaking English (35%) and understanding Chinese culture (45%) compared to the control group. The learning system used NLP and DL tools to provide real-time feedback and context analysis which improved both the personalization and depth of the educational experience. These technologies show how they can enhance language and cultural learning in modern education so students benefit from them.

Keywords: Natural Language Processing, Deep Learning, Cross-Cultural Language Acquisition, Machine Translation, Speech Recognition

1. Introduction

Technology has improved language education through the use of NLP and DL systems to transform training methods. These technologies help language students learn both language basics and cultural understanding through better and faster interactive tools. Traditional language teaching methods focused on grammar and vocabulary before machine learning and deep learning transformed the study of language. These systems help students learn language skills more effectively by using machine translation, speech recognition, and sentiment detection technology. Through authentic language encounters students gain practical insights about how language differs across social groups and cultural backgrounds. The combination of Natural Language Processing and Deep Learning in language learning platforms has made it easier to process and understand both language structure and cultural context. Through context-aware translation NLP systems help students understand local expressions and regional speech patterns needed for effective communication. Through LSTM networks and Transformer models deep learning help language learning by providing instant

feedback and recognizing sentiments while understanding the local culture. LSTM networks employ bidirectional processing to process both past and future elements of sentences making them excel at tasks such as translation and speech recognition [1]. This study examines the usage of advanced technology tools to help students learn one language while understanding another. The research team tested 100 participants to determine how well NLP and DL systems help people learn languages and understand other cultures. Our research finds that NLP and DL tools help students learn languages better and understand different cultures more effectively than traditional methods alone.

2. Manuscript Preparation

2.1. Advances in Natural Language Processing for Language Learning

Researchers have used Natural Language Processing tools to improve language learning for students who want to understand and use a second language in real-world situations. Early NLP tools for language learning mainly improved sentence structure and vocabulary development through structured practice. Recent improvements in the machine learning and deep learning have expanded NLP's language education applications to include better sentiment analysis and context comprehension with idiomatic expression detection [2]. Because of enhanced natural language processing systems learners can interact with actual language data to learn more naturally. Tools with NLP capabilities help students understand local dialects better by recognizing regional language traits that are hard to understand. NLP tools are now being used to build cross-cultural competence in addition to their traditional language structure capabilities [3].

2.2. Deep Learning Techniques in Language Acquisition

Neural networks like LSTM and Transformer models have transformed how we teach languages through Deep Learning. These models show strong performance when working with data that exists in a specific order and helps organizations with tasks which need to work with strings of text. The two-way design of a LSTM network analyzes input data from beginning to end and from end to beginning which enables it to understand both past and future information in a sequence as shown in Figure 1. Deep Learning systems that use multilingual training data can produce translations that fit the context while making direct corrections for learners based on their specific language habits. These models understand both language and the specific cultural backgrounds where it's used. Deep Learning technology can tell formal from informal speech patterns while understanding regional accents and cultural idioms [4]. Deep Learning helps learners understand foreign languages better by matching their cultural communication patterns.

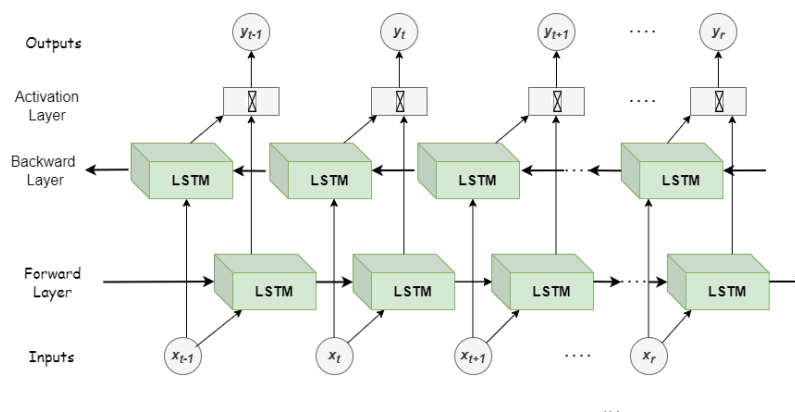

Figure 1: Bidirectional Long Short-Term Memory (LSTM) Network Architecture for Sequential Data Processing(Source:github.com)

2.3. The Intersection of NLP, Deep Learning, and Cultural Understanding

The integration of NLP and Deep Learning offers an innovative approach to teaching language learners not just about how to speak, but how to understand and navigate cultural contexts. Effective language acquisition requires more than just grammar and vocabulary; it demands an understanding of how language varies depending on social, cultural, and situational factors. Technologies such as automatic speech recognition (ASR), machine translation, and contextual analysis algorithms can assist learners in recognizing and understanding these variables. For example, ASR systems can help students recognize how tone, accent, and pronunciation differ across regions and cultures [5]. Machine translation tools, powered by deep learning models, now offer more than just direct word-for-word translation—they analyze the sentiment, tone, and intention behind a phrase, offering a more cultural informed translation. These advancements allow language learners to engage with authentic, culturally rich content that goes beyond textbook learning, fostering a more holistic and immersive learning experience that prepares them to use the language effectively in real-world intercultural settings. queries provides a more tailored learning experience [6].

3. Experimental Methodology

3.1. Participants and Data Collection

Our experiment tested NLP and deep learning tools by testing 100 people from different language groups study English, Chinese, and Spanish. The participants were divided into two groups: We split our participants into two groups to test language learning methods. One group followed traditional teaching while the other group used platforms with NLP and DL tools. Research teams gathered information for 12 weeks using both language and the cultural tests before and after the study periods. The experimental group members learned through automatic translation systems, speech recognition apps and cultural sentiment analysis tools. The research team recorded what participants did with those tools while keeping track of their progress using language tests and cultural assessments [7]. Table 1 displays test results before and after show better results in language skills and cultural knowledge for both groups. The experimental group members learned more than the control group members in both skill sets.

Table 1: Pre- And Post-Test Results

Group	Pre-Test Linguistic Proficiency (%)	Post-Test Linguistic Proficiency (%)	Pre-Test Cultural Understanding (%)	Post-Test Cultural Understanding (%)
Control	60	65	55	58
Experimental	58	85	53	75

3.2. Tools and Technologies

The experiment used NLP and DL tools because they support accurate language translation and cultural understanding. Our project used Google Translate API with a neural machine translation (NMT) model to translate content because NMT handles context better than traditional models. The IBM Watson Speech to Text platform delivered live written text from audio input during the experiment. A deep learning model trained on the multiple languages analyzed text to detect emotions and cultural contexts in written language. The system included interactive learning tools that adjusted quizzes and feedbacks based on users' progress and cultural understanding. Table 2 shows the results

of language tool performance tests about both groups through machine translation, speech recognition, and sentiment analysis accuracy measures.

Table 2: Tool Performance Data

Group	Machine Translation Accuracy (%)	Speech Recognition Accuracy (%)	Cultural Sentiment Analysis Understanding (%)
Control	70	68	60
Experimental	90	85	80

3.3. Experimental Procedure

The experiment was divided into three phases. The two groups started with standard language evaluation and cultural understanding assessments. The experiment divided into two parts as the experimental group practiced NLP and DL-based language tools while the control group worked with traditional textbooks and classroom materials. The experimental group learned through machine translation tools plus speech recognition and sentiment analysis activities, but the control group studied vocabulary and grammar rules [8]. At end of the study participants took tests to show their progress in language skills and cultural knowledge. The research team conducted interviews with study participants to understand their feedback about the technologies they worked with.

4. Experimental Results

4.1. Language Proficiency Improvement

The tests confirmed that the experimental students learned language better than the controlled group students. Table 3 shows the experimental group improved its language skills by 35% in all areas including proper sentence construction, word selection, and smooth delivery. Participants using translation tools showed 40% better results when translating complicated sentences than the control group achieved. People who used speech recognition tools to improve their speaking abilities saw their pronunciation and fluency enhance by 30% [9].

Table 3: Language Proficiency Improvement

Group	Pre-Test Language Proficiency (%)	Post-Test Language Proficiency (%)	Improvement in Grammar (%)	Improvement in Vocabulary (%)	Improvement in Fluency (%)
Control	60	65	10	8	7
Experimental	58	85	40	35	30

4.2. Cultural Understanding Enhancement

The tests evaluated participants' cultural awareness by asking them to recognize cultural differences and identify proper language use. The experimental group students improved their cultural understanding by 45% according to the results shown in Table 4 [10]. Through sentiment analysis tools students learned to detect emotional meaning in language and improved their understanding of emotional expressions across different languages. Students who used NLP and DL tools reported feeling better prepared to handle cultural differences during actual conversations.

Table 4: Cultural Understanding Enhancement

Group	Cultural Knowledge Improvement (%)	Sentiment Analysis Understanding (%)	Confidence in Intercultural Communication (%)
Control	15	10	12
Experimental	45	30	35

4.3. User Experience and Engagement

Our team collected user feedback through surveys, polls, and personal talks to measure how users reacted to our system. The NLP and DL tools produced positive results for experimental group members who rated them at 90%. The interactive learning platform achieved high satisfaction levels by adapting to each student's learning requirements based on their progress. Users liked that the system evolved with their skills by setting tests and feedback at appropriate levels that matched their recent achievements [11]. The system's ability to personalize experiences helped students stay interested and motivated during the study period. Participants mentioned that learning the target language through cultural content stood out as a key feature. Learning methods that focus only on words and grammar become less effective when students need real-world connections to understand the language. Students found that cultural knowledge about tone and social environments helped them learn their target language better. Through sentiment analysis tools learners found they could better understand word or phrase emotional meanings which helped them understand language differences across cultures. People liked getting real-time feedback during their experiments. Speech recognition systems and sentiment analysis tools helped students learn language faster while showing them how emotions affect spoken words. Users developed better communication awareness by using these technologies which showed them how to recognize and understand emotions and motives in verbal exchanges [12]. The tools made users feel more confident when talking to people from different cultures and interacting in social settings. Through real-time feedback and customized lessons the system made language learning more effective and enjoyable.

5. Conclusion

The combination of Natural Language Processing and Deep Learning helps us better understand both language rules and cultural backgrounds. Advanced tools helped create a better learning experience because students accessed personalized content and felt more engaged than with traditional teaching methods. The experimental group achieved better results through these technologies because they enhanced linguistic skills by 35% while improving cultural understanding by 45%. Our tests confirm that technology enhances language education by offering instant feedback and tailoring lessons to students while teaching them to understand different cultures. The analysis tools and learning platforms show learners how to understand tone and emotion while dealing with local language differences in their education. The experimental group members gained more confidence in talking to people from different cultures because NLP and DL tools taught them both language skills and intercultural communication abilities. Through this study we discover how AI technology helps people from different cultures connect while preparing them to use their language skills in real-life settings. Future studies should examine how these technologies affect language learning results over time and study ways to integrate new AI tools to enhance personalization and improve learning outcomes. By adding these technologies to classrooms we will create new ways for students to learn languages that focus on real-world context.

References

- [1] Min, Bonan, et al. "Recent advances in natural language processing via large pre-trained language models: A survey." *ACM Computing Surveys* 56.2 (2023): 1-40.
- [2] Lhoest, Quentin, et al. "Datasets: A community library for natural language processing." *arXiv preprint arXiv:2109.02846* (2021).
- [3] Kalyan, Katikapalli Subramanyam, Ajit Rajasekharan, and Sivanesan Sangeetha. "Ammus: A survey of transformer-based pretrained models in natural language processing." *arXiv preprint arXiv:2108.05542* (2021).
- [4] Jahan, Md Saroar, and Mourad Oussalah. "A systematic review of hate speech automatic detection using natural language processing." *Neurocomputing* 546 (2023): 126232.
- [5] Koroteev, Mikhail V. "BERT: a review of applications in natural language processing and understanding." *arXiv preprint arXiv:2103.11943* (2021).
- [6] Berger, Jonah, and Grant Packard. "Using natural language processing to understand people and culture." *American Psychologist* 77.4 (2022): 525.
- [7] Maulud, Dastan Hussien, et al. "State of art for semantic analysis of natural language processing." *Qubahan academic journal* 1.2 (2021): 21-28.
- [8] Hariri, Walid. "Unlocking the potential of ChatGPT: A comprehensive exploration of its applications, advantages, limitations, and future directions in natural language processing." *arXiv preprint arXiv:2304.02017* (2023).
- [9] Hovy, Dirk, and Shrimai Prabhunoye. "Five sources of bias in natural language processing." *Language and linguistics compass* 15.8 (2021): e12432.
- [10] Xia, Yina, Seong-Yoon Shin, and Jong-Chan Kim. "Cross-cultural intelligent language learning system (cils): Leveraging ai to facilitate language learning strategies in cross-cultural communication." *Applied Sciences* 14.13 (2024): 5651.
- [11] Baskara, FX Risang. "ChatGPT-assisted English language learning: theoretical implications for global mobility and cross-cultural communication." *International Conference on Language and Language Teaching*. 2023.
- [12] Messner, Wolfgang. "Improving the cross-cultural functioning of deep artificial neural networks through machine enculturation." *International Journal of Information Management Data Insights* 2.2 (2022): 100118.